

STATIC ELIMINATORS

**Powerful and high quality static eliminators with, and without air amplification products,
To address virtually any application which static charges are a problem.**

WHAT ARE THEY - REASONS TO USE

Wild claims are made by some amplification product suppliers that putting a static bar with an Air Knife will eliminate static at incredible distances which are highly exaggerated. We will attempt to clarify such myths with reality.

A static eliminator is a device that produces ions - positive and negative - which neutralize any opposite charge on a surface that these ions interact with. Static charges occur on plastic parts, moving webs of paper and film, and can cause problems of jamming as well as shock hazards to personnel.

Charges can vary on a surface and in some cases (depending on a variety of factors such as material, speed, and humidity) be extremely high. For this reason Nex Flow™ has several options to address the wide variety of environments encountered.

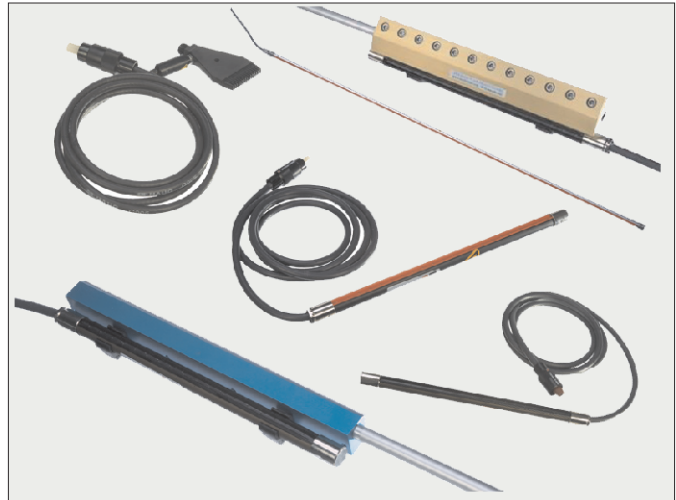

Nex Flow™ has a variety of static elimination products to address virtually any static application in manufacturing

MYTH VERSES REALITY

Static Eliminators are used on their own when they can be placed close to a surface. In all instances it takes “time” for the static to dissipate. When close to a surface it can happen extremely quickly (milliseconds). This can usually be achieved by using a standard strength static bar. In some cases the surface charge may be extremely high (like in some materials as Mylar) and/or the surface may be moving quite quickly on a moving web. In such cases the static bar may not produce enough “ions” fast enough and a more powerful static bar is required. Just adding an Air Knife will NOT speed up static removal. In fact it may slow it down! Nex Flow™ has available a more powerful static bar for such high charged” or high speed applications.

Adding a compressed air “Air Knife” will allow you to remove static at a distance (as will adding a blower) but can increase the time needed to dissipate static as the ions somewhat recombine on their way to the target weakening their effect. Therefore often a stronger static bar (that we can provide) is required.

All static control equipment meets electrical standards for North America and/or Europe and are ROHS compliant.



Nex Flow™ uses quality static bars from Haug rather than cheap products because Haug static bars have been proven to last in difficult environments. The most fragile part of any ionization system is the static bar and Haug bars have proven themselves against many others to be durable, of high quality, and long lasting.

THE MODEL RN STATIC BAR

The HAUG **RN** Ionizing Bar is a powerful and rugged piece of equipment. Production interfering surface charges can be removed reliably and effectively - even at high operating speeds. The coaxial high-voltage plug-and-socket connection of the HAUG system **X-2000** offers a unique advantage in that the gas tight high-voltage plug can be connected to the HAUG power pack easily and without tools. The flexible, coaxially shielded cable connects the ionizing unit with the voltage supply. The flexible, coaxially shielded cable connects the ionizing unit with the voltage supply. The round construction of the RN ionizing bar permits the exact axial adjustment in the direction of travel of the material. The Ionizing Bar is safe to touch. Special wear-resistant electrodes guarantee long service life.



MODEL RN Static Bar



MODEL VS Static Bar

THE MODEL VS EXTRA POWERFUL STATIC BAR

The HAUG **VS** Ionizing Bar reliably removes electrostatic charges and its performance, when compared to the standard version, is three times the power. This tremendously improves the static removal and designed to address extremely high charges, faster speeds and greater distances. The **VS** Ionizing Bar has all of the typical features that characterize HAUG Ionizing Bars: the reliable and removable plug-and-socket connection System **X-2000**, the shielded high-voltage cable, the special stainless-steel electrodes and the convenience of being safe to touch. The electrical capacity of the VS Ionizing Bar is three times as great as the standard version, and therefore, it is necessary to base any power pack load calculations on a bar length three times as long.

EXPLOSION PROOF STATIC BARS AND POWER SUPPLIES

The Haug **El Ex T** ionizing units are approved for equipment in areas with potential explosive atmospheres, to eliminate unwanted electrostatic charges where hazardous gases may form, such as paint facilities or printing machines utilizing solvent inks.

The design of the **El Ex T** Ionizing Bar complies with the international ATEX directives in combination with the Model EN 92 or Multistat Ex power supplies. This system is approved for use in manufacturing locations with potentially explosive atmospheres resulting from gases of explosion group IIA, temperature classes T4 to T6.



MODEL EX T Static Bar

MODEL RN STANDARD STRENGTH STATIC BAR

PART NO.	DESCRIPTION
13003	Haug Model RN Static Bar - 4" LONG
13006	Haug Model RN Static Bar - 7" LONG
13009	Haug Model RN Static Bar - 10" LONG
13012	Haug Model RN Static Bar - 13" LONG
13018	Haug Model RN Static Bar - 19" LONG
13024	Haug Model RN Static Bar - 25" LONG
13030	Haug Model RN Static Bar - 31" LONG
13036	Haug Model RN Static Bar - 37" LONG
13042	Haug Model RN Static Bar - 43" LONG
13048	Haug Model RN Static Bar - 49" LONG
13054	Haug Model RN Static Bar - 55" LONG
13060	Haug Model RN Static Bar - 61" LONG
13066	Haug Model RN Static Bar - 67" LONG
13072	Haug Model RN Static Bar - 73" LONG
13078	Haug Model RN Static Bar - 79" LONG
13084	Haug Model RN Static Bar - 85" LONG

MODEL VS EXTRA STRENGTH STATIC BAR

PART NO.	DESCRIPTION
14006	Haug Model VS Static Bar - 7" LONG
14009	Haug Model VS Static Bar - 9" LONG
14012	Haug Model VS Static Bar - 13" LONG
14018	Haug Model VS Static Bar - 19" LONG
14024	Haug Model VS Static Bar - 25" LONG
14030	Haug Model VS Static Bar - 31" LONG
14036	Haug Model VS Static Bar - 37" LONG
14042	Haug Model VS Static Bar - 43" LONG
14048	Haug Model VS Static Bar - 49" LONG
14054	Haug Model VS Static Bar - 55" LONG
14060	Haug Model VS Static Bar - 61" LONG
14066	Haug Model VS Static Bar - 67" LONG
14072	Haug Model VS Static Bar - 73" LONG
14078	Haug Model VS Static Bar - 79" LONG
14084	Haug Model VS Static Bar - 85" LONG

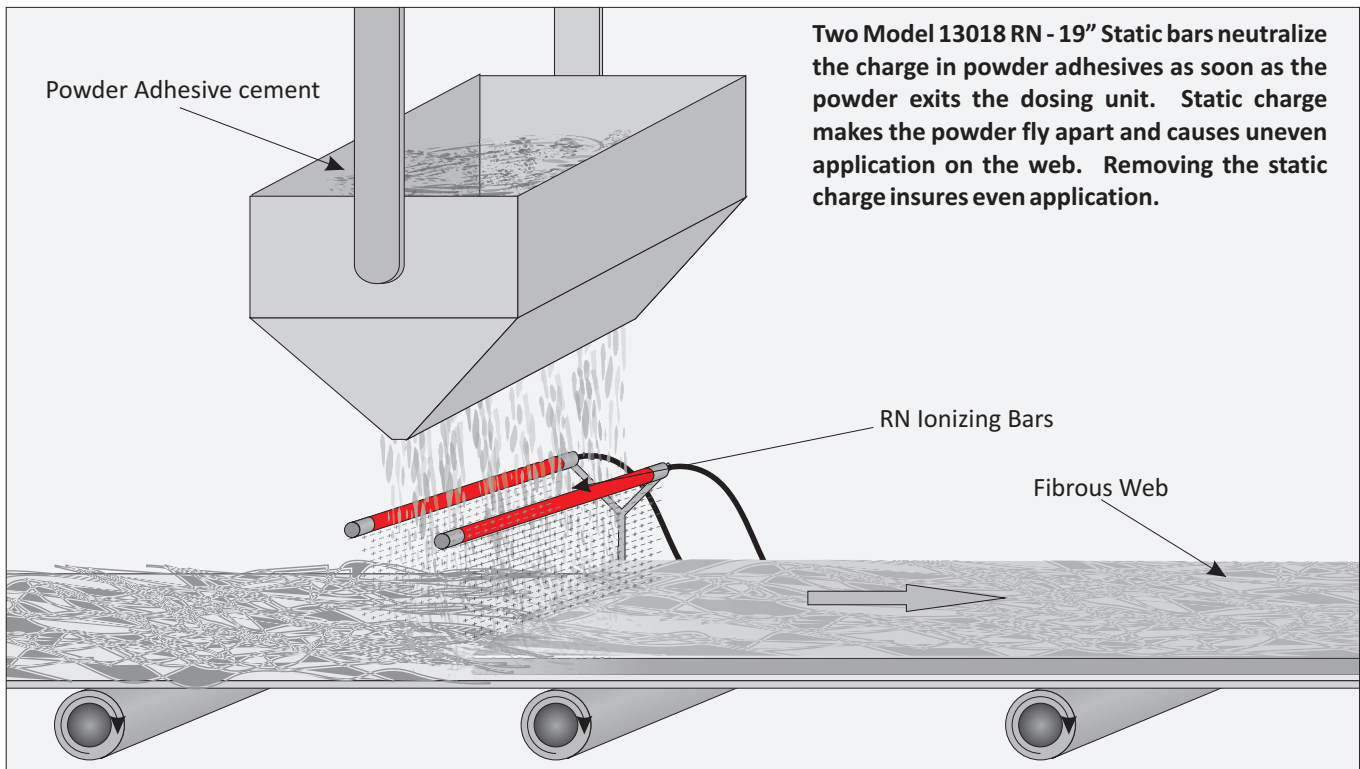

Two Model 13018 RN - 19" Static bars neutralize the charge in powder adhesives as soon as the powder exits the dosing unit. Static charge makes the powder fly apart and causes uneven application on the web. Removing the static charge insures even application.

For Explosion Proof applications consult Factory or your local representative

E-mail:- ■ sales@nexflow.com ■ sales@nexflowair.com ■ sales@nex-flow.com

Web:- ■ www.nexflow.com ■ www.nexflowair.com ■ www.nex-flow.com

Nex Flow™ uses quality Power Supplies from Haug that have several unique features unavailable in competitive units.

Haug Power Supplies are:

- 1. **Repairable** - parts are replaceable
- 2. **Several versions** - units available with four outlets, two outlets, with or without function monitoring, and in 220V and 110V versions
- 3. **Patent Safety X-2000 Connection** - prevents accidental shocks when connecting or disconnecting a static eliminator to the power supply
- 4. **High Reliability and Life** - so reliable that we even offer a two year warranty on the power supplies

High Voltage Power Pack Transformers EN - C (2 outlet) and EN-C4 (4 outlet)

Static Control Power Supply EN-C type High Voltage Power Pack. The integrated high-voltage transformer covers applied mains voltage to approx. 7,000 to 8,000 volts. The unit is equipped with two or four high-voltage terminals and integrated on - off pilot lamp.

Transformers are equipped with a modular-type high-voltage transformer. It consists of three main modules, all of which can be replaced individually. This unit is electrically approved for North American installations.



S-Line power pack EN SL

The **S-Line power pack** comes with two high-voltage connections and meets both North American and European standards. The integrated high-voltage transformer covers applied mains voltage to approx. 7,000 to 8,000 volts. Integrated on - off pilot lamp.

S-Line power pack EN SL LC - Same as the SL, but with integrated full-electronic function monitoring to constantly monitor all functions of the ionizing system. It alerts the operator of any irregularities by causing the LED indicator integrated in the housing to flash

EN SL RLC - Identical in all technical aspects to the EN SL LC plus a signal socket above the earthing sleeve. A fault message can be connected to the signal socket.





MULTISTAT POWER SUPPLY



EN - 92 EX POWER SUPPLY

Power pack EN 92 Ex is suitable for direct use in areas with potentially explosive atmospheres (zones 1 or 2).

The units comply with the International ATEX directives. All high-voltage components are accommodated in a flameproof housing. The power pack **EN 92 Ex** is equipped with two high-voltage ports for the connection of the ionizing units. No long high-voltage cables are required, as the power pack can be installed in the immediate vicinity of the ionizing unit.

POWER SUPPLIES

North American Approved	
PART NO.	DESCRIPTION
80111	Haug Model ENC-2, 110V, 2-outlet power supply
80112	Haug Model ENC 4, 110V, 4-outlet power supply
80121	Haug Model ENC-2, 220V, 2-outlet power supply
80122	Haug Model ENC 4, 220V, 4-outlet power supply

Multistat Power Supply

The **Multistat** power pack provides the optimum in power pack performance and monitoring. The **Multistat EX** is approved for explosion proof applications (but must be mounted outside the explosion proof area).

Special features and advantages

- ▶ Self-balancing high-voltage; no adjustment or settings on the Multistat are required
- ▶ Indication of the output high-voltage by means of an analogue indicating instrument
- ▶ Fault indication in case of insufficient output voltage by means of an optical signal (light-emitting diode - LED) and a floating change-over contact
- ▶ Fault indication in case of insufficient mains voltage by means of a floating change-over contact
- ▶ The floating change-over contact allow both status check and an error check to be performed
- ▶ The **Multistat** allows the integration of the fault signals into a quality assurance system
- ▶ The high-voltage plug-and-socket connector system **X-2000** ensures a secure connection.
- ▶ Four high-voltage terminals

Function Monitoring

For an ionization system to work efficiently, a voltage of at least 4.2 kV (Corona inception voltage) is required. By monitoring the electronic control of the output voltage, the high-voltage is continuously monitored; any drop below the corona inception voltage is signaled as malfunction. This fault signal may be linked with the machine control system or the production monitoring system using the socket connection integrated into the housing and a signaling cable.

North American and European Approved	
PART NO.	DESCRIPTION
80321	S-Line EN-SL, 110V, 2-outlet power supply
80322	S-Line EN-SL, 220V, 2-outlet power supply
80421	S-Line EN SL LC, 110V, 2-outlet power supply
80422	S-Line EN SL LC, 220V, 2-outlet power supply
80221	Haug Multistat, 4-outlet, 110V power supply
80222	Haug Multistat, 4-outlet, 220V power supply

For Explosion Proof applications contact Factory or local Representative

E-mail:- ▪ sales@nexflow.com ▪ sales@nexflowair.com ▪ sales@nex-flow.com

Web:- ▪ www.nexflow.com ▪ www.nexflowair.com ▪ www.nex-flow.com

SILENT X-STREAM™ AIR BLADE™ IONIZER

Powerful and quiet static eliminator rapidly dissipates static charge and removes dust.

The Silent X-Stream™ Air-Blade™ Air Knife utilizes the quality Haug static bars - the RN bar for most applications or the extra strong VS bars (Triple X versions) for very high static charges and extremely high speeds. The Silent X-Stream™ Air-Blade™ Air Knife uses a small amount of compressed air for a powerful, and adjustable force with "laminar" flow to eliminate charges in applications where static bars cannot reach or where high speeds are a factor, and to clean the surface.

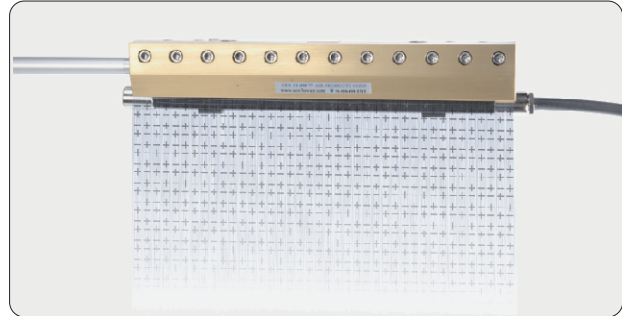

Normally the Standard Model RN Haug brand static bar can address most applications. For extremely high speeds and high charges the extra powerful VS model is used. For wash down applications (such as pharmaceutical areas), a washable model is available at extra cost. **(Contact factory for information)**

All Haug static bars come with a patented safety connector and fully shielded cable. The power supplies are "repairable" and are so well made, that we offer a two year warranty on them (one year on the bars).

SILENT X-STREAM™ AIR-BLADE™ IONIZER FEATURES:

- ▶ Connections on the back or ends
- ▶ It flows from end to end (full flow).
- ▶ Stainless steel models are available for high temperature and corrosive environments.
- ▶ Models are designed for easy cleaning and prevention of dirt entering the static bar, minimizing potential damage.
- ▶ Patented connectors with the ground intrinsic to the cable design.
- ▶ Instant ON/OFF with no moving parts.
- ▶ Repairable Power Supply with a two year warranty.

SILENT X-STREAM™ AIR-BLADE™ IONIZER BENEFITS:

- ▶ Flexible mounting options.
- ▶ Units can be mounted end to end for longer lengths with no air gap.
- ▶ High temperature, extra strength, and even a unique washable stainless steel model is available for special applications or as required.
- ▶ Ease of cleaning and maintenance.
- ▶ No separate ground connection that can be cut and cause sparks or accidentally shock personnel
- ▶ Conserves air use when not required.
- ▶ Eliminates one costly area which is power supply replacement. 2 year warranty on power supplies.

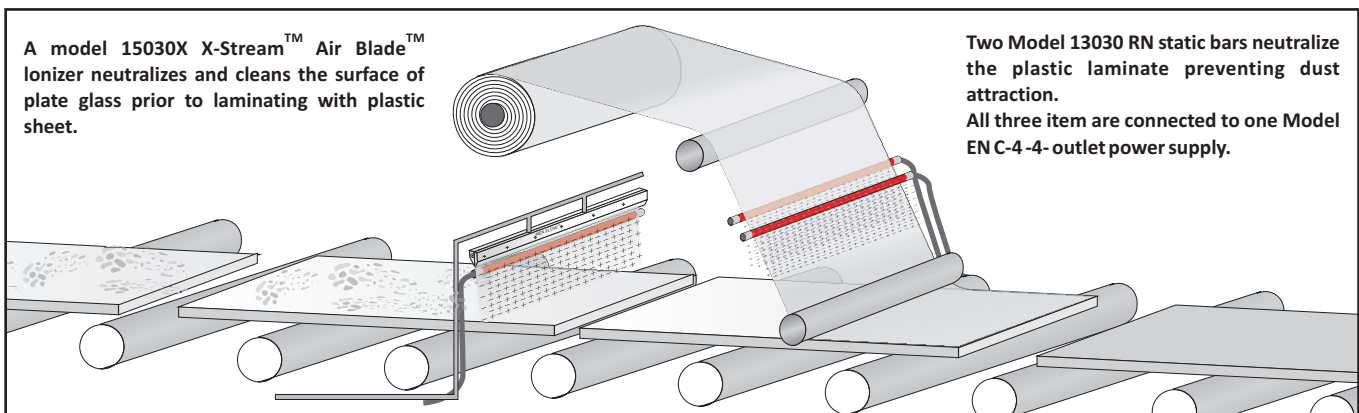

A model 15030X X-Stream™ Air Blade™ Ionizer neutralizes and cleans the surface of plate glass prior to laminating with plastic sheet.

Two Model 13030 RN static bars neutralize the plastic laminate preventing dust attraction. All three items are connected to one Model EN C-4 -4- outlet power supply.

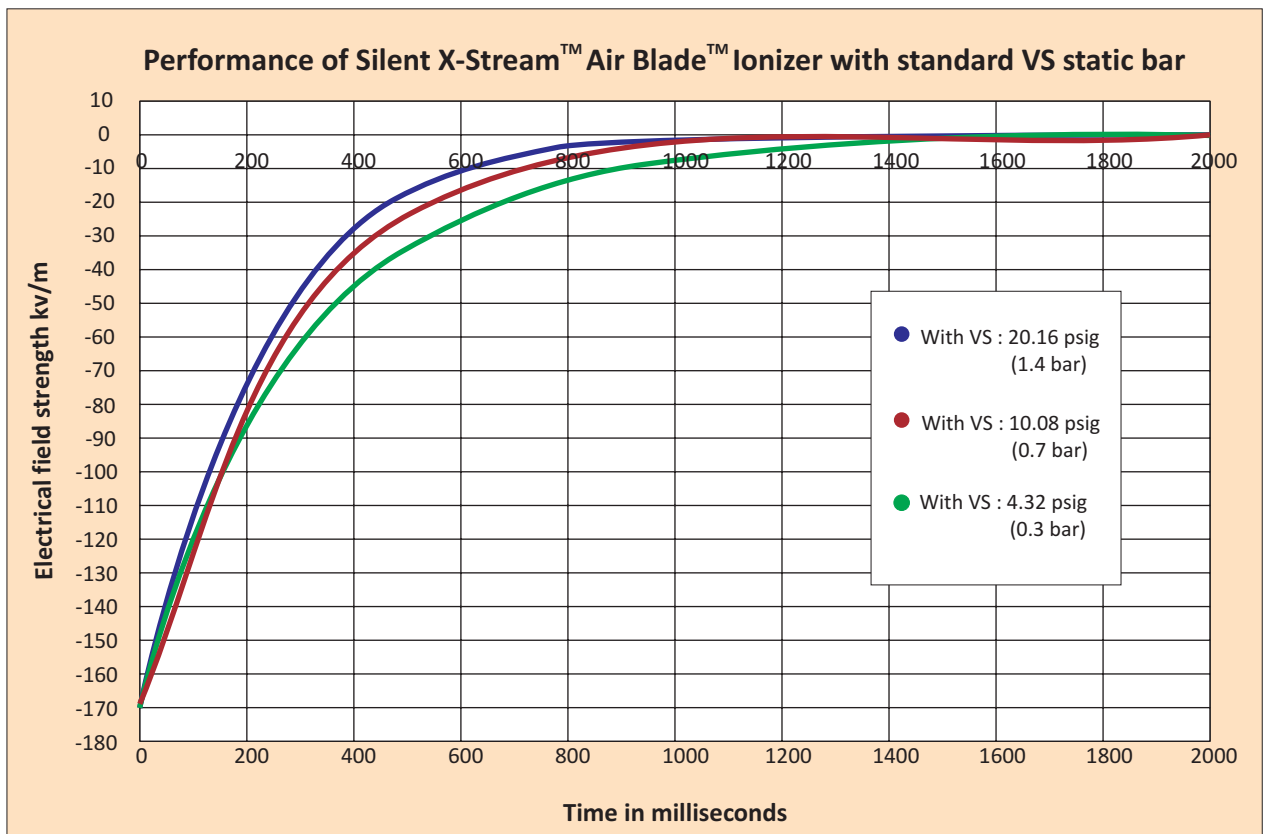
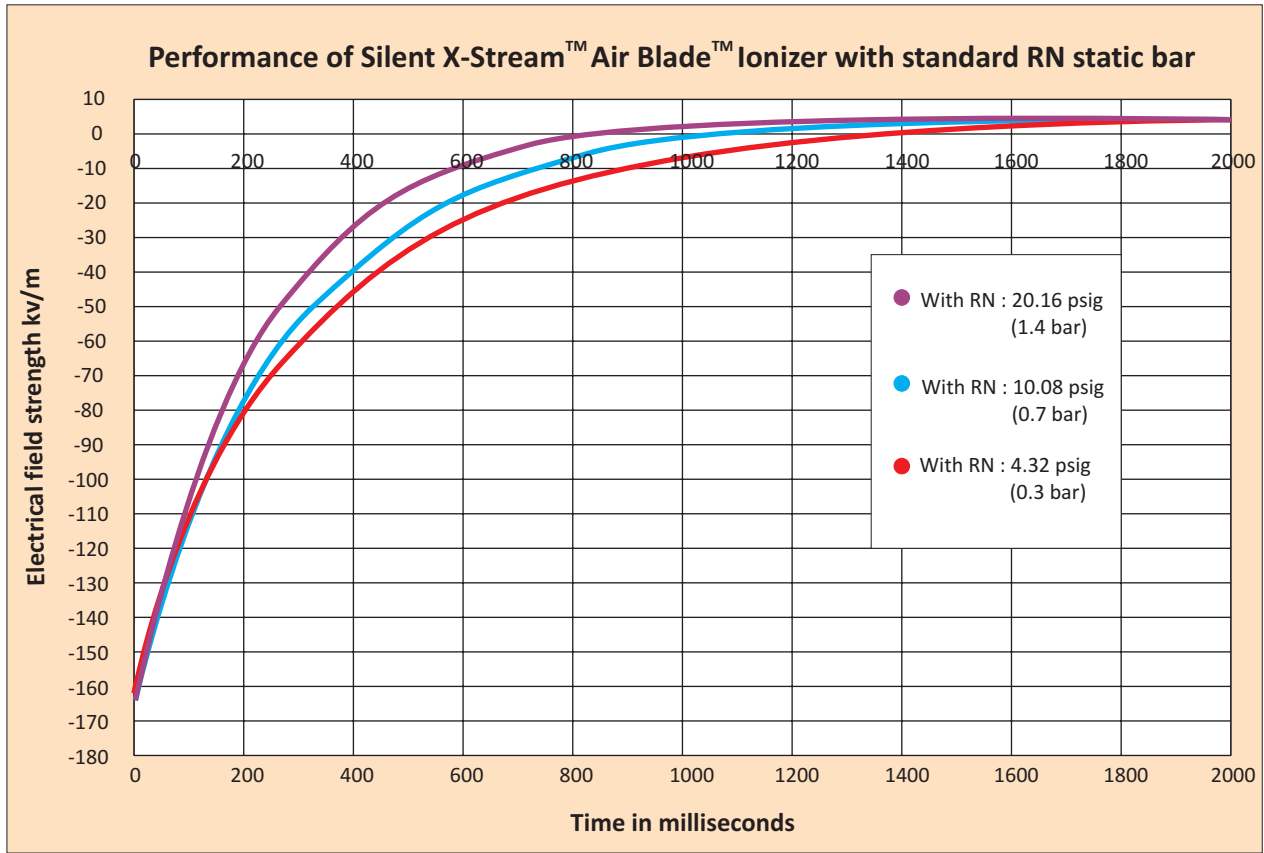

STATIC ELIMINATORS

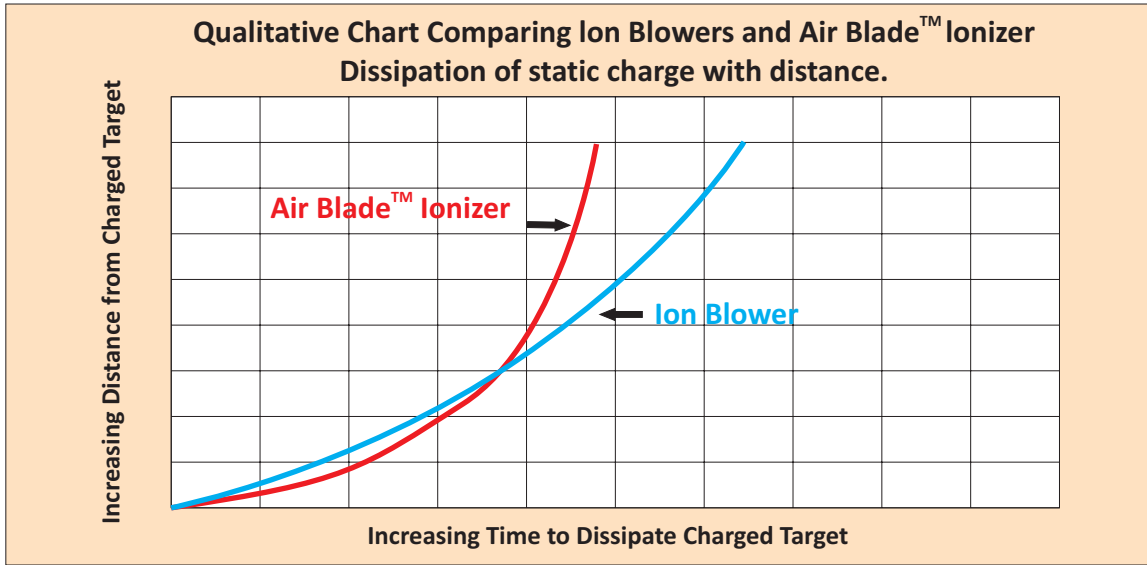

PERFORMANCE AND RELIABILITY

The standard RN static bar is very effective when mounted close to a surface (within an inch) at speeds up to 800 feet per minute and the strong VS bar can work to speeds up to 2000 feet per minute mounted as close or at slower speeds up to 8 inches away. For greater distances and high speeds the addition of air is required. The laminar flow from an Air Blade™ Air Knife will extend the effectiveness over this extra distance. Even with laminar flow the ions will recombine and slow static dissipation slightly. For very highly charged surfaces and very high speeds, the extra strong VS static bar may be required. Apart from distance, the Air Blade™ Air Knife allows enough force for blow-off of dust and dirt with little required. Blowers can actually be more effective in static removal closer to the surface but the Air Blade™ Ionizer is more effective when further away (see chart comparing blowers and Air Blade™ Ionizers above). This is why we recommend stronger static bars like our VS static bar for blowers when far from the target. Blowers however do not offer adequate blow-off force to clean unless they have very high flow and high static pressure. But when not close to the target, blower systems will still require a stronger static bar to match the rate of dissipation that an Air Blade™ Ionizer can offer. The X-Stream™ Air Blade™ Ionizer can work well for dust and dirt blow-off within the range of 20 to 40 PSIG (1.4 to 2.8 Bar) line pressure.

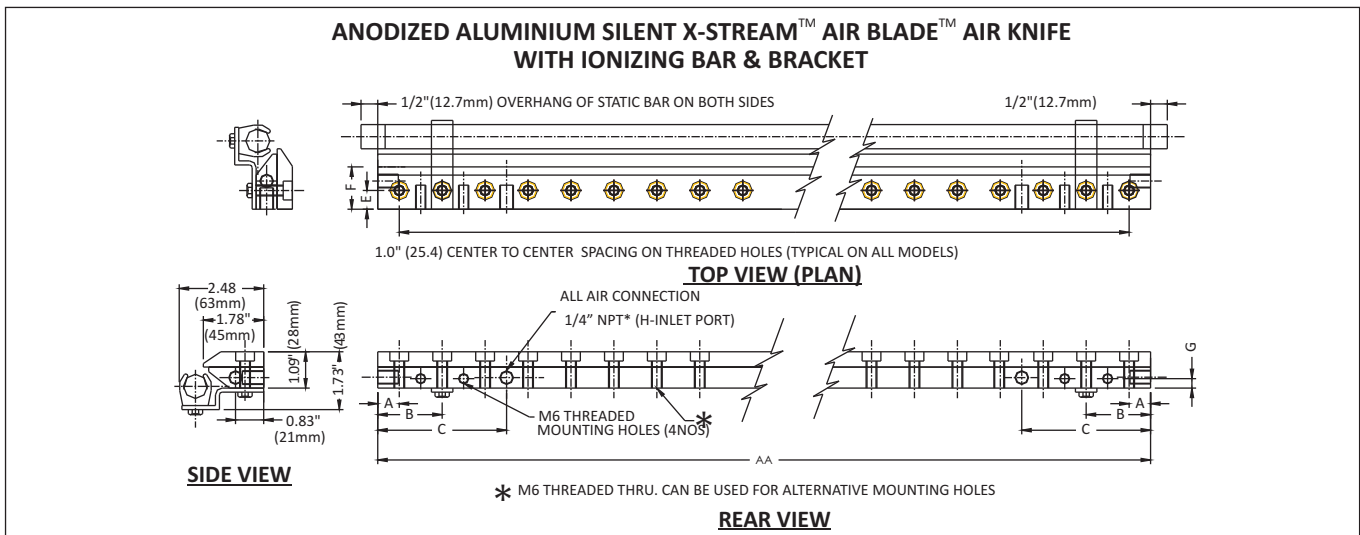

For Air Knife Dimensions please refer page B4

(* BSP Threads or Adaptors can be supplied depending on country location)

X-STREAM™ AIR BLADE™ IONIZERS

PART NO.	DESCRIPTION
15003X	One 3" X-Stream™ Air Blade™ c/w Model RN Static Bar
15006X	One 6" X-Stream™ Air Blade™ c/w Model RN Static Bar
15009X	One 9" X-Stream™ Air Blade™ c/w Model RN Static Bar
15012X	One 12" X-Stream™ Air Blade™ c/w Model RN Static Bar
15018X	One 18" X-Stream™ Air Blade™ c/w Model RN Static Bar
15024X	One 24" X-Stream™ Air Blade™ c/w Model RN Static Bar
15030X	One 30" X-Stream™ Air Blade™ c/w Model RN Static Bar
15036X	One 36" X-Stream™ Air Blade™ c/w Model RN Static Bar
15042X	One 42" X-Stream™ Air Blade™ c/w Model RN Static Bar
15048X	48" (Two 24") X-Stream™ Air Blade™ c/w Model RN Static Bar
15054X	54" (One 24" & One 30") X-Stream™ Air Blade™ c/w Model RN Static Bar
15060X	60" (Two 30") X-Stream™ Air Blade™ c/w Model RN Static Bar
15066X	66" (One 30" & One 36") X-Stream™ Air Blade™ c/w Model RN Static Bar
15072X	72" (Two 36") X-Stream™ Air Blade™ c/w Model RN Static Bar
15078X	78" (One 36" & One 42") X-Stream™ Air Blade™ c/w Model RN Static Bar
15084X	84" (Two 42") X-Stream™ Air Blade™ c/w Model RN Static Bar
15103X	3" X-Stream™ Air Blade™ Ionizer plus ENC-2 Power Supply
15106X	6" X-Stream™ Air Blade™ Ionizer plus ENC-2 Power Supply
15109X	9" X-Stream™ Air Blade™ Ionizer plus ENC-2 Power Supply
15112X	12" X-Stream™ Air Blade™ Ionizer plus ENC-2 Power Supply
15118X	18" X-Stream™ Air Blade™ Ionizer plus ENC-2 Power Supply
15124X	24" X-Stream™ Air Blade™ Ionizer plus ENC-2 Power Supply
15130X	30" X-Stream™ Air Blade™ Ionizer plus ENC-2 Power Supply
15136X	36" X-Stream™ Air Blade™ Ionizer plus ENC-2 Power Supply
15142X	42" X-Stream™ Air Blade™ Ionizer plus ENC-2 Power Supply
15148X	48" X-Stream™ Air Blade™ Ionizer plus ENC-2 Power Supply
15154X	54" X-Stream™ Air Blade™ Ionizer plus ENC-2 Power Supply
15160X	60" X-Stream™ Air Blade™ Ionizer plus ENC-2 Power Supply
15166X	66" X-Stream™ Air Blade™ Ionizer plus ENC-2 Power Supply
15172X	72" X-Stream™ Air Blade™ Ionizer plus ENC-2 Power Supply
15178X	78" X-Stream™ Air Blade™ Ionizer plus ENC-2 Power Supply
15184X	84" X-Stream™ Air Blade™ Ionizer plus ENC-2 Power Supply

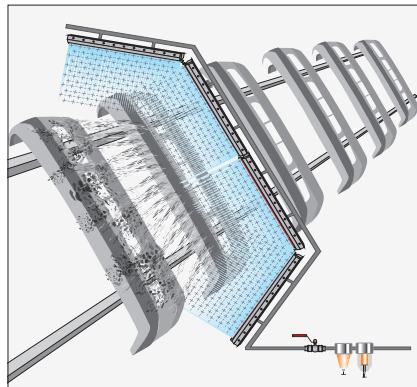

Three 24" X-Stream™ Air Blade™ Ionizers Blow off dust from Automotive Bumpers prior to painting. The NEX FLOW™ PLCFC controls the air on and off as required minimizing air consumption. In this case the static bars were "daisy-chained" together minimizing extraneous cable and reducing the number of power supplies needed.

STATIC ELIMINATORS

SUPER TRIPLE X-STREAM™ AIR BLADE™ IONIZERS

PART NO.	DESCRIPTION
16006X	One 6" Super Triple X-Stream™ Air Blade™ c/w Model VS Static Bar
16009X	One 9" Super Triple X-Stream™ Air Blade™ c/w Model VS Static Bar
16012X	One 12" Super Triple X-Stream™ Air Blade™ c/w Model VS Static Bar
16018X	One 18" Super Triple X-Stream™ Air Blade™ c/w Model VS Static Bar
16024X	One 24" Super Triple X-Stream™ Air Blade™ c/w Model VS Static Bar
15030X	One 30" Super Triple X-Stream™ Air Blade™ c/w Model VS Static Bar
16036X	One 36" Super Triple X-Stream™ Air Blade™ c/w Model VS Static Bar
16042X	One 42" Super Triple X-Stream™ Air Blade™ c/w Model VS Static Bar
16048X	48" (Two 24") Super Triple X-Stream™ Air Blade™ c/w Model VS Static Bar
16054X	54" (One 24" & One 30") Super Triple X-Stream™ Air Blade™ c/w Model VS Static Bar
16060X	60" (Two 30") Super Triple X-Stream™ Air Blade™ c/w Model VS Static Bar
16066X	66" (One 30" & One 36") Super Triple X-Stream™ Air Blade™ c/w Model VS Static Bar
16072X	72" (Two 36") Super Triple X-Stream™ Air Blade™ c/w Model VS Static Bar
16078X	78" (One 36" & One 42") Super Triple X-Stream™ Air Blade™ c/w Model VS Static Bar
16084X	84" (Two 42") Super Triple X-Stream™ Air Blade™ c/w Model VS Static Bar
16106X	6" Super Triple X-Stream™ Air Blade™ Ionizer plus ENC-2 Power Supply
16109X	9" Super Triple X-Stream™ Air Blade™ Ionizer plus ENC-2 Power Supply
16112X	12" Super Triple X-Stream™ Air Blade™ Ionizer plus ENC-2 Power Supply
16118X	18" Super Triple X-Stream™ Air Blade™ Ionizer plus ENC-2 Power Supply
16124X	24" Super Triple X-Stream™ Air Blade™ Ionizer plus ENC-2 Power Supply
16130X	30" Super Triple X-Stream™ Air Blade™ Ionizer plus ENC-2 Power Supply
16136X	36" Super Triple X-Stream™ Air Blade™ Ionizer plus ENC-2 Power Supply
16142X	42" Super Triple X-Stream™ Air Blade™ Ionizer plus ENC-2 Power Supply
16148X	48" Super Triple X-Stream™ Air Blade™ Ionizer plus ENC-2 Power Supply
16154X	54" Super Triple X-Stream™ Air Blade™ Ionizer plus ENC-2 Power Supply
16160X	60" Super Triple X-Stream™ Air Blade™ Ionizer plus ENC-2 Power Supply
16166X	66" Super Triple X-Stream™ Air Blade™ Ionizer plus ENC-2 Power Supply
16172X	72" Super Triple X-Stream™ Air Blade™ Ionizer plus ENC-2 Power Supply
16178X	78" Super Triple X-Stream™ Air Blade™ Ionizer plus ENC-2 Power Supply
16184X	84" Super Triple X-Stream™ Air Blade™ Ionizer plus ENC-2 Power Supply

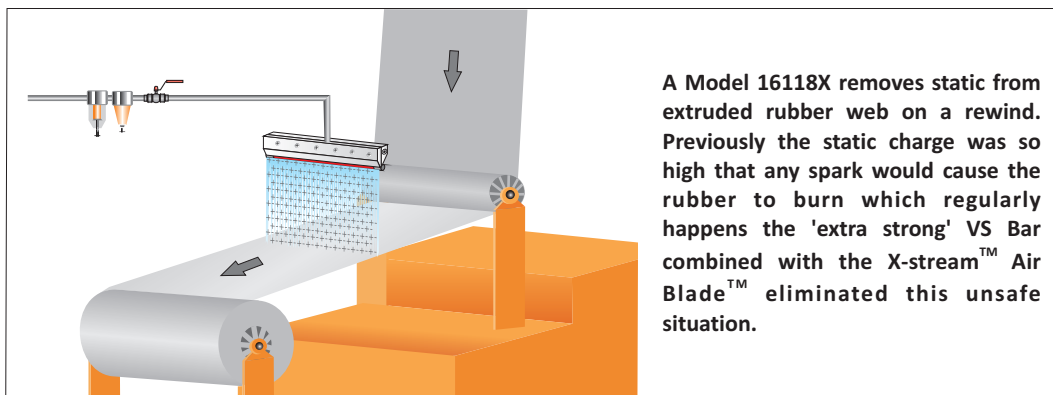

A Model 16118X removes static from extruded rubber web on a rewind. Previously the static charge was so high that any spark would cause the rubber to burn which regularly happens the 'extra strong' VS Bar combined with the X-stream™ Air Blade™ eliminated this unsafe situation.

STANDARD AIR BLADE™ IONIZER

A Low Cost but powerful static eliminator that rapidly removes static charge and cleans

The Standard Air Blade™ Ionizer combines the superior designed Standard Air Blade™ Air Knife the quality Haug static bars - the RN bar for most applications or the extra strong VS bars (Triple X versions) for very high static charges and extremely high speeds. The standard Air-Blade™ Air Knife uses slightly more compressed air than the Silent X-Stream™ Air Blade™ and has a higher sound level but still produces a powerful, and adjustable force with "laminar" flow to eliminate charges in applications where static bars cannot reach or where high speeds are a factor.

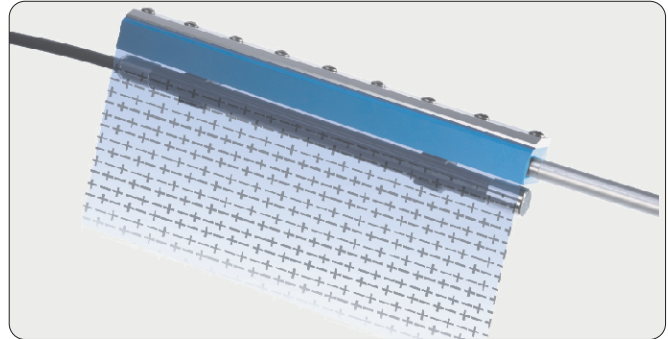

Normally the Standard Model RN Haug brand static bar can address most applications. For extremely high speeds and high charges the extra powerful VS model is used. For wash down applications (such as pharmaceutical areas), a washable model is available at extra cost. **(Contact factory for information)**

All Haug static bars come with a patented safety connector and fully shielded cable. The power supplies are "repairable" and are so well made, that we offer a two year warranty on them (one year on the bars).

STANDARD AIR BLADE™ IONIZER FEATURES:

- ▶ Connections on the back or ends.
- ▶ It flows from end to end (full flow).
- ▶ Stainless steel models are available for high temperature and corrosive models.
- ▶ Models are designed for easy cleaning and prevention of dirt entering the static bar, minimizing potential damage.
- ▶ Patented connectors with the ground intrinsic to the cable design.
- ▶ Instant ON/OFF with no moving parts.
- ▶ Repairable Power Supply with a two year warranty.

STANDARD AIR BLADE™ IONIZER BENEFITS:

- ▶ Flexible mounting options.
- ▶ Units can be mounted end to end for longer lengths with no air gap.
- ▶ High temperature, extra strength, and even a unique washable stainless steel model is available for special applications or as required.
- ▶ Ease of cleaning and maintenance.
- ▶ No separate ground connection that can be cut and cause sparks or accidentally shock personnel.
- ▶ Conserves air use when not required.
- ▶ Eliminates one costly area which is power supply replacement. 2 year warranty on.

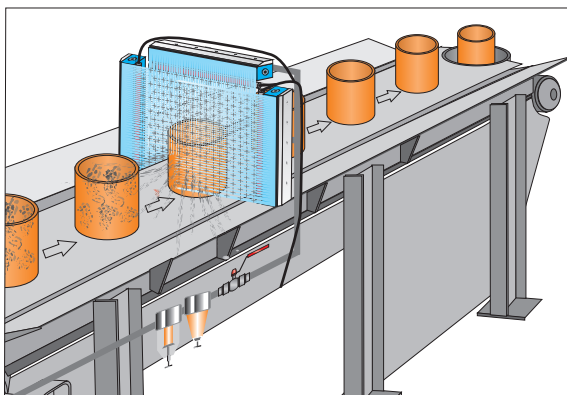

Three Model 15012 Standard Air Blade™ ionizer with 'extra strong' model VS static bar is used to remove the static charge from containers moving at high speed prior to filling. The ionized air is blown in to the container to remove the static charge. All the static bars will connect with 4 outlet power supply. The VS Bars have to be used because of the high speed of container.

STATIC ELIMINATORS

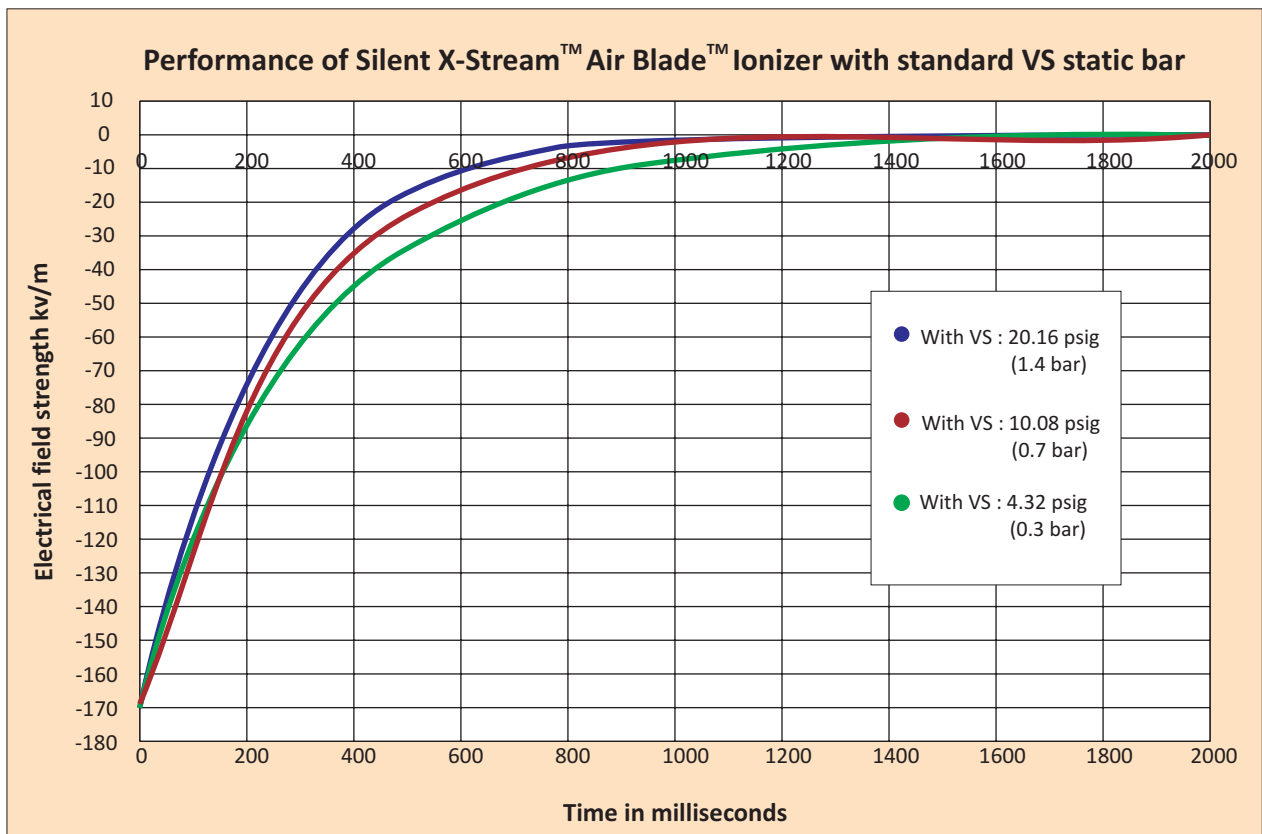
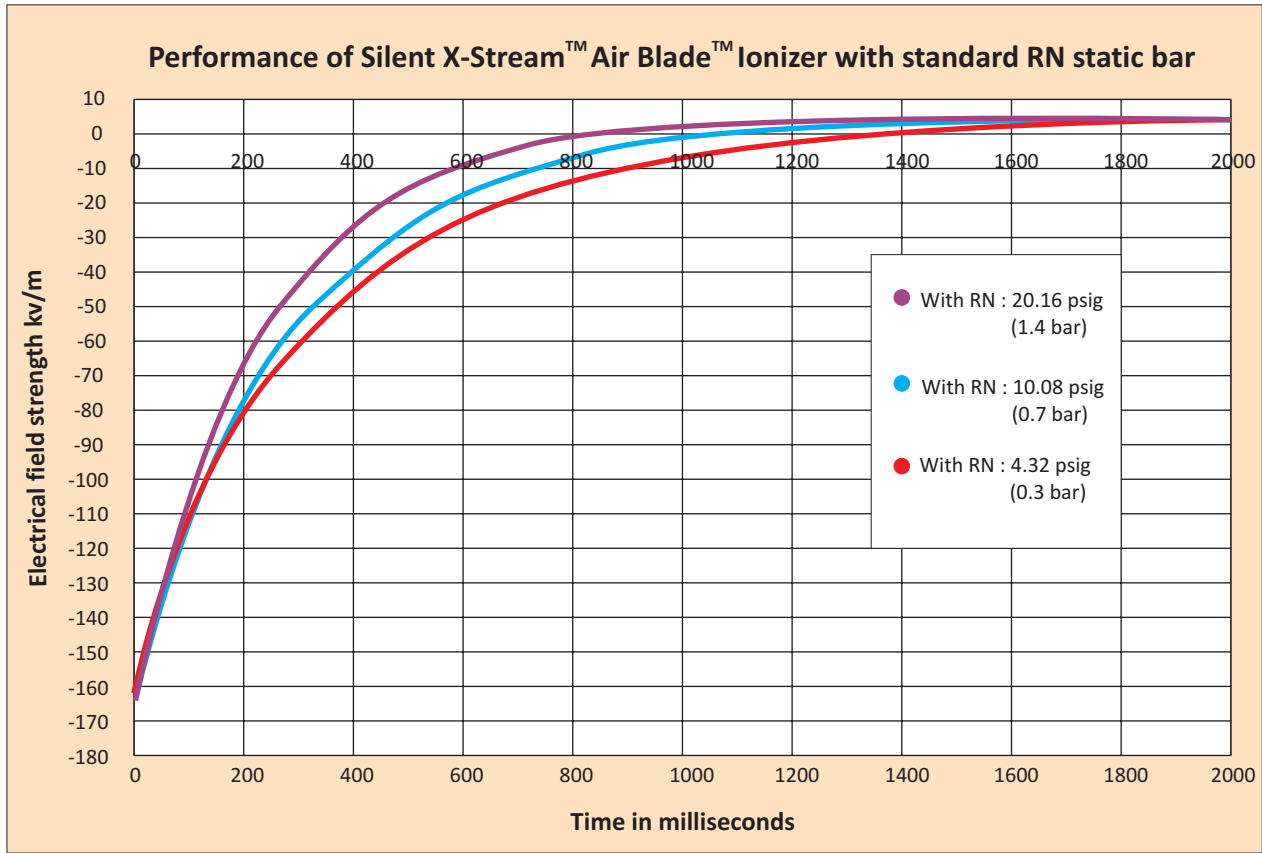

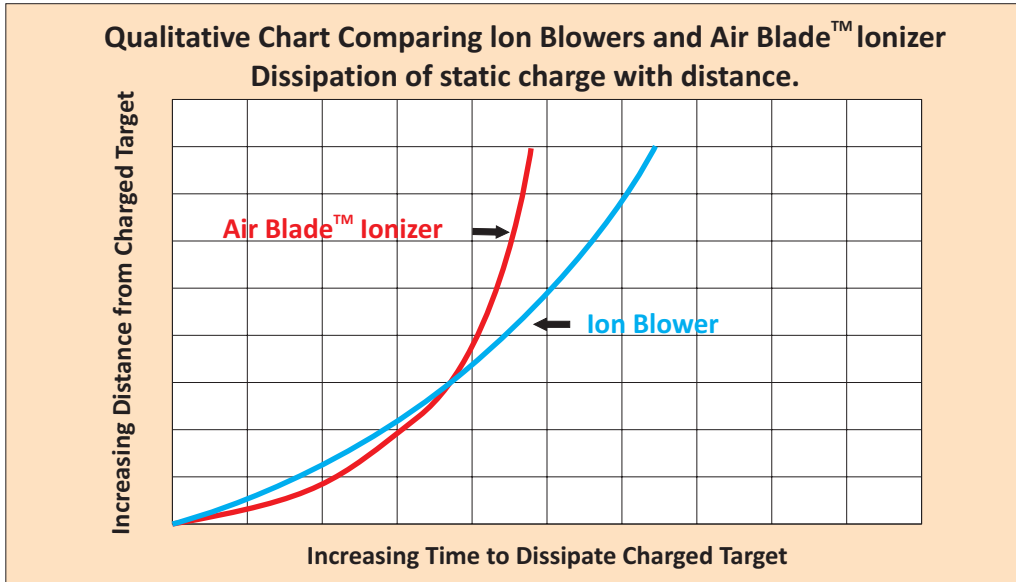

PERFORMANCE AND RELIABILITY

The standard RN static bar is very effective when mounted close to a surface (within an inch) at speeds up to 800 feet per minute and the strong VS bar can work to speeds up to 2000 feet per minute mounted as close or at slower speeds up to 8 inches away. For greater distances and high speeds the addition of air is required. The laminar flow from an Air Blade™ Air Knife will extend the effectiveness over this extra distance. Even with laminar flow the ions will recombine and slow static dissipation slightly. For very highly charged surfaces and very high speeds, the extra strong VS static bar may be required. Apart from distance, the Air Blade™ Air Knife allows enough force for blowoff of dust and dirt with little required. Blowers can actually be more effective in static removal closer to the surface but the Air Blade™ Ionizer is more effective when further away (see chart comparing blowers and Air Blade™ Ionizers above). This is why we recommend stronger static bars like our VS static bar for blowers when far from the target. Blowers however do not offer adequate blowoff force to clean unless they have very high flow and high static pressure. But when not close to the target, blower systems will still require a stronger static bar to match the rate of dissipation that an Air Blade™ Ionizer can offer. The Standard Air Blade™ Ionizer can work well for dust and dirt blowoff within the range of 20 to 40 PSIG (1.4 to 2.8 Bar) line pressure.

STATIC ELIMINATORS

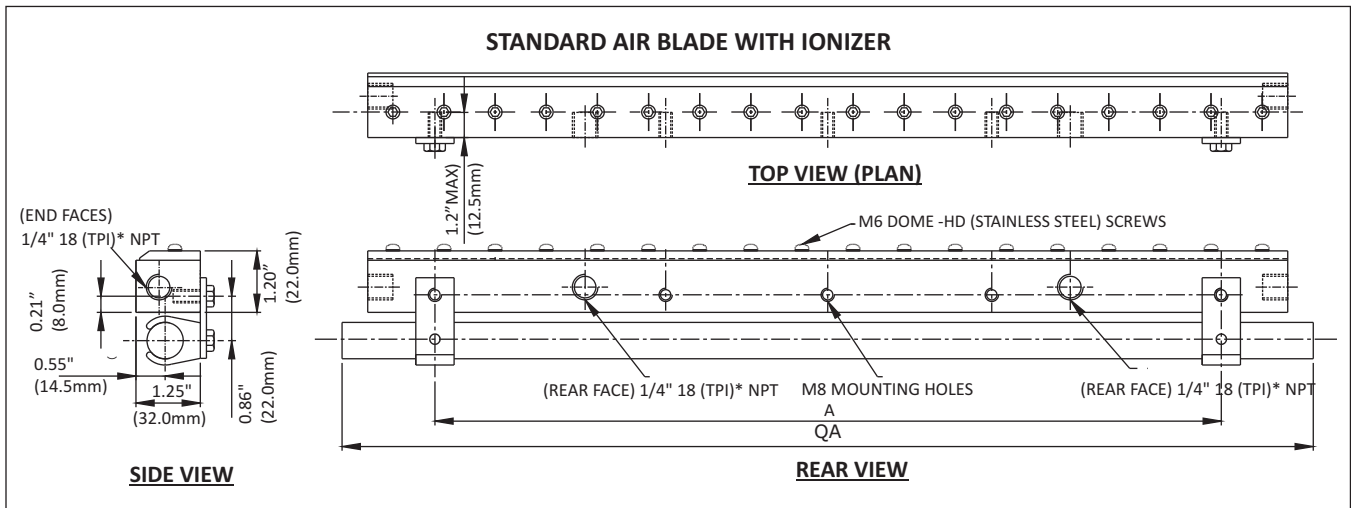

For Air Knife Dimensions please refer page B15

(* BSP Threads or Adaptors can be supplied depending on country location)

STANDARD AIR BLADE™ IONIZERS

PART NO.	DESCRIPTION
15003	One 3" Standard Air Blade™ c/w Model RN Static Bar
15006	One 6" Standard Air Blade™ c/w Model RN Static Bar
15012	One 12" Standard Air Blade™ c/w Model RN Static Bar
15018	One 18" Standard Air Blade™ c/w Model RN Static Bar
15024	One 24" Standard Air Blade™ c/w Model RN Static Bar
15030	One 30" Standard Air Blade™ c/w Model RN Static Bar
15036	One 36" Standard Air Blade™ c/w Model RN Static Bar
15042	42" (One 24" & one 18") Standard Air Blade™ c/w Model RN Static Bar
15048	48" (Two 24") Standard Air Blade™ c/w Model RN Static Bar
15054	54" (One 24" & One 30 Standard Air Blade™ c/w Model RN Static Bar
15060	60" (Two 30 Standard Air Blade™ c/w Model RN Static Bar
15066	66" (One 30" & One 36") Standard Air Blade™ c/w Model RN Static Bar
15072	72" (Two 36") Standard Air Blade™ c/w Model RN Static Bar
15103	3" Standard Air Blade™ Ionizer plus ENC-2 Power Supply
15106	6" Standard Air Blade™ Ionizer plus ENC-2 Power Supply
15112	12 Standard Air Blade™ Ionizer plus ENC-2 Power Supply
15118	18" Standard Air Blade™ Ionizer plus ENC-2 Power Supply
15124	24" Standard Air Blade™ Ionizer plus ENC-2 Power Supply
15130	30" Standard Air Blade™ Ionizer plus ENC-2 Power Supply
15136	36" Standard Air Blade™ Ionizer plus ENC-2 Power Supply
15142	42" Standard Air Blade™ Ionizer plus ENC-2 Power Supply
15148	48" Standard Air Blade™ Ionizer plus ENC-2 Power Supply
15154	54" Standard Air Blade™ Ionizer plus ENC-2 Power Supply
15160	60" Standard Air Blade™ Ionizer plus ENC-2 Power Supply
15166	66" Standard Air Blade™ Ionizer plus ENC-2 Power Supply
15172	72" Standard Air Blade™ Ionizer plus ENC-2 Power Supply

SUPER TRIPLE STANDARD AIR BLADE™ IONIZERS

PART NO.	DESCRIPTION
16006	One 6" Super Triple Standard Air Blade™ c/w Model VS Static Bar
16012	One 12" Super Triple Standard Air Blade™ c/w Model VS Static Bar
16018	One 18" Super Triple Standard Air Blade™ c/w Model VS Static Bar
16024	One 24" Super Triple Standard Air Blade™ c/w Model VS Static Bar
16030	One 30" Super Triple Standard Air Blade™ c/w Model VS Static Bar
16036	One 36" Super Triple Standard Air Blade™ c/w Model VS Static Bar
16042	42" (One 24" & one 18") Super Triple Standard Air Blade™ c/w Model VS Static Bar
16048	48" (Two 24") Super Triple Standard Air Blade™ c/w Model VS Static Bar
16054	54" (One 24" & One 30") Super Triple Standard Air Blade™ c/w Model VS Static Bar
16060	60" (Two 30") Super Triple Standard Air Blade™ c/w Model VS Static Bar
16066	66" (One 30" & One 36") Super Triple Standard Air Blade™ c/w Model VS Static Bar
16072	72" (Two 36 Super Triple Standard Air Blade™ c/w Model VS Static Bar
16106	6" Super Triple Standard Air Blade™ Ionizer plus ENC-2 Power Supply
16112	12" Super Triple Standard Air Blade™ Ionizer plus ENC-2 Power Supply
16118	18" Super Triple Standard Air Blade™ Ionizer plus ENC-2 Power Supply
16124	24" Super Triple Standard Air Blade™ Ionizer plus ENC-2 Power Supply
16130	30" Super Triple Standard Air Blade™ Ionizer plus ENC-2 Power Supply
16136	36" Super Triple Standard Air Blade™ Ionizer plus ENC-2 Power Supply
16142	42" Super Triple Standard Air Blade™ Ionizer plus ENC-2 Power Supply
16148	48" Super Triple Standard Air Blade™ Ionizer plus ENC-2 Power Supply
16154	54" Super Triple Standard Air Blade™ Ionizer plus ENC-2 Power Supply
16160	60" Super Triple Standard Air Blade™ Ionizer plus ENC-2 Power Supply
16166	66" Super Triple Standard Air Blade™ Ionizer plus ENC-2 Power Supply
16172	72" Super Triple Standard Air Blade™ Ionizer plus ENC-2 Power Supply

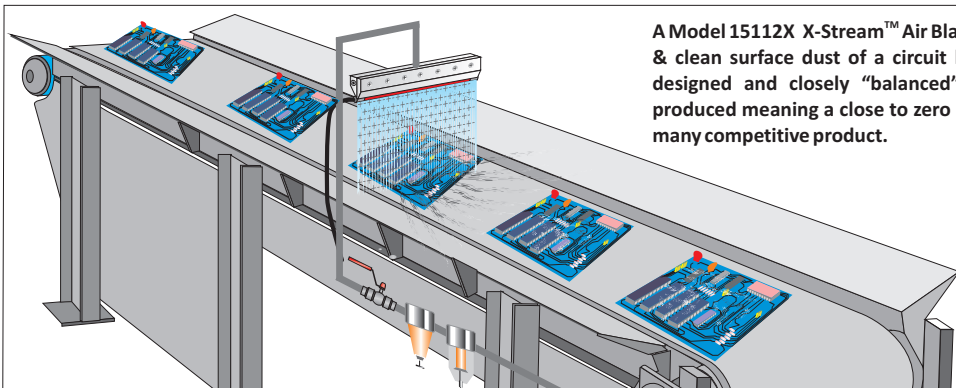

A Model 15112X X-Stream™ Air Blade™ Ionizer is used to neutralize & clean surface dust of a circuit board. The ionizing bar is well designed and closely "balanced" in positive & negative ions produced meaning a close to zero residual charge after use unlike many competitive product.

STATIC ELIMINATORS

ION BLASTER BEAM™ - Quiet, Super Efficient, Concentrated flow of ionized air to eliminate static charge and remove dust!



ION BLASTER BEAM™ APPLICATIONS

- Eliminate static charge and cleaning parts
- Neutralize shrink wrap
- Form fill and seal applications for bag opening
- Neutralizing and cleaning the inside of blow molded parts
- Eliminate static and cleaning of plastic assemblies
- Dust removal from parts prior to painting
- Remove static charge in slitting applications
- Cleaning of packaging
- Neutralization of static charge inside containers

WHAT ARE THEY - REASONS TO USE

The *Nex Flow™ Ion Blaster Beam™* neutralizes static electricity and can remove static free dust up to 15 feet (4.6 m) away with no moving parts. It's compact design allows it to be used in hard to reach areas or confined spaces. The air volume and velocity are infinitely adjustable over a wide range using a pressure regulator to address any application from light to heavy duty. The use of an "air amplifier" (Model AM40) maximizes ionized airflow with large volume entrained while minimizing the use of compressed air. (See Air Amplifiers elsewhere in the catalog). In most applications only 10 psig (0.7 bar) is required to operate effectively. The Ionizing Point is a powerful ionizer which remains effective because the air exit "plastic PET head" of the unit prevents weakening if ions which metal attachments may do. This can make the *Ion Blaster Beam™* far more effective than systems using metal

ION BLASTER BEAM™ FEATURES

- Effective Static Elimination
- Can clean static free dust at a distance
- Compact Design to fit in small spaces
- Stand is pre-drilled for easy mounting

ION BLASTER BEAM™ BENEFITS

- Low compressed air use
- Rapid static decay
- Quiet Operation
- Shockless and non-radioactive
- Compact and rugged design
- Intake may be ducted to bring in atmospheric air from another area
- no moving parts and minimal maintenance
- Variable flow and force

DIMENSIONS

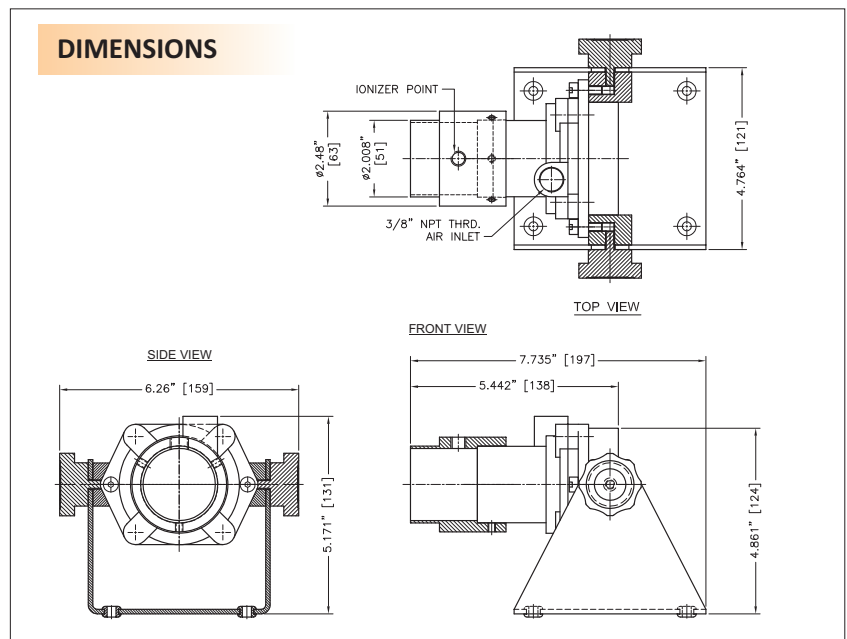

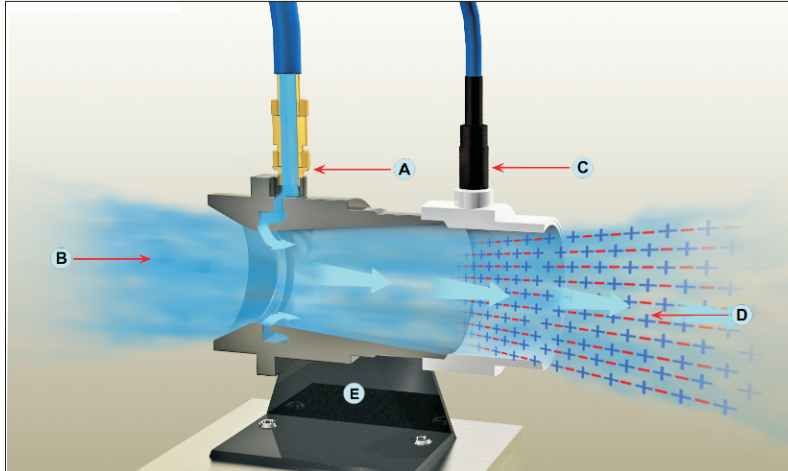

HOW IT WORKS

Compressed air is supplied at (A) where it enters the air amplifier section of the Ion Blaster Beam and follows the Coanda profile inside the amplifier. Ambient air is entrained at (B) into the amplifier. The Ionizing Point (C) ionizes the amplified airflow exiting as a powerful high flow of static removing, ionized air ay (D). Unit is mounted on a stand (E) for convenient installation.

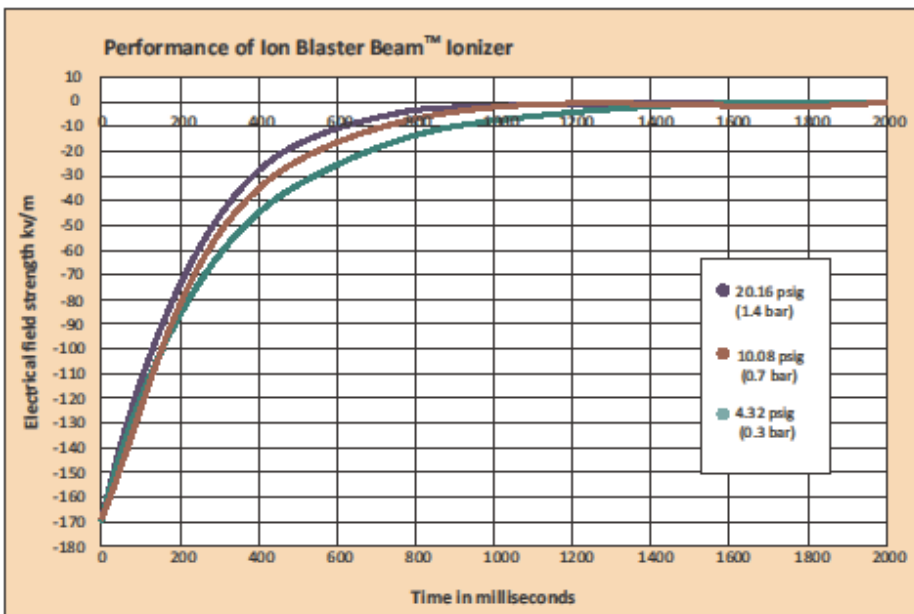

STATIC ELIMINATORS

PART NO.	DESCRIPTION
17040	Ion Blaster Beam™ includes Air Amplifier, Spot Ionizer. Stand and 2 Meters shielded cable.
17140	Ion Blaster Beam™ and Power Supply
17340	Ion Blaster Beam™ Kit (c/w Ion Blaster Beam™, Power Supply, Model 90001 water removal filter and Model 90008 regulator wi. gage
80111	120 V Power Supply, 2 outlet
80121	230V Power Supply, 2 outlet
80112	120 V Power Supply, 4 outlet
80122	230 V Power Supply, 4 outlet
90001	Water Removal Filter c/w auto Drain
90008	Water Removal Filter c/w auto Drain

ION AIR BLASTER BEAM™ SPECIFICATIONS

Certification: North American Power Supplies certified to UL and CSA standards and Spot Ionizer used with the Ion Blaster beam is included with the certification. European Power Supplies CE approved and Spot Ionizer used with the Ion Blaster Beam is included with the certification. Stainless steel emitters on the ionizer.

Electrical: For use with 7 kV rms, 5 milliamperes (max) power supply which will last much longer than 5 kv power supplies.

Electrical Hazard: Shockless (less or eualt to 5mA)

Maximum Ambient Temperature: 122 degrees F or 50 degrees C.

THE LG LIGHT-WEIGHT ERGONOMETRIC DESIGNED IONIZING AIR GUN IS EFFICIENT AND REPAIRABLE

THE LG “LIGHT-WEIGHT GUN” IONIZING AIR GUN

The LG ionizing Air Gun is light weight at only 16 oz (480 gm) (before air hose and high voltage cable) and easy to handle. If damaged it is easily repairable by replacing one of only seven parts.

Ionizing Air Gun Function

The head of the device is enclosed by a sheet material shield, which serves both as mechanical protection and counter-electrode. Due to the special shape of this shield, bypass channels are created, which assist an efficient six-channel blowing nozzle by stabilizing the airflow. The airflow can be adjusted exactly in accordance to the application - particularly useful for the treatment of small pieces.



Ionizing Air Gun Special Features and Advantages

- ▶ **Operating facility** : The LG Gun consists of few individual modules, each of which is exchangeable. The high-voltage cable can be extended, shortened or exchanged.
- ▶ **Ergonomic** : Modern industrial design well thought-out down to the last detail. This device can be used conveniently and efficiently by left and right handed persons.
- ▶ **Efficient Air Amplification** : The utilization of the intake air through bypass channels
- ▶ **Lightweight and quiet** : The LG creates remarkably little noise and its low weight makes it easy to handle.

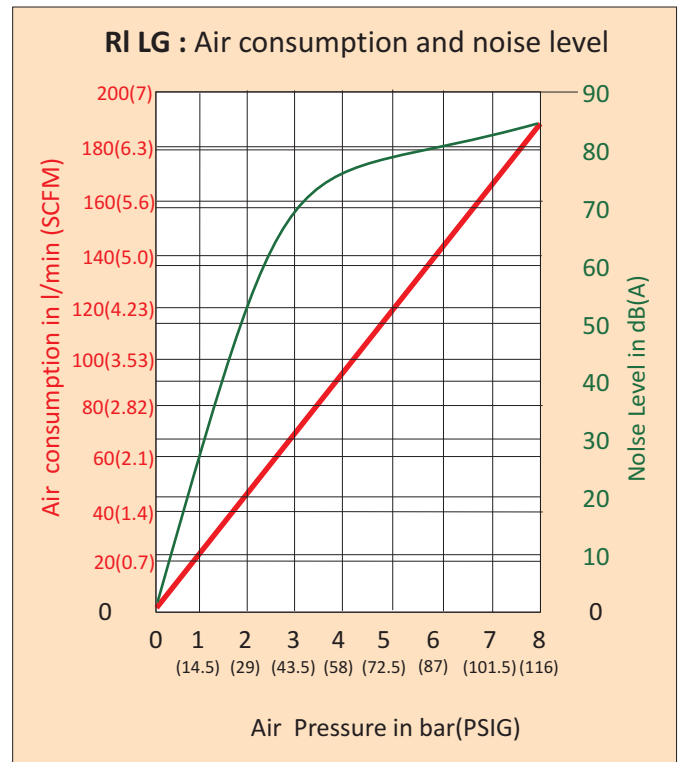

SPECIAL NOTES:

The LG Gun as all Haug products, all come with a patented connector to assure safety in operation and maintenance. Field repairable, it prevents a connection if the static gun is removed or attached while power is still on at the power supply. Lightweight and highly flexible cable is FULLY SHIELDED for longer life.

REPAIRABLE POWER SUPPLIES

Power supplies are repairable and come with a 2 year warranty.

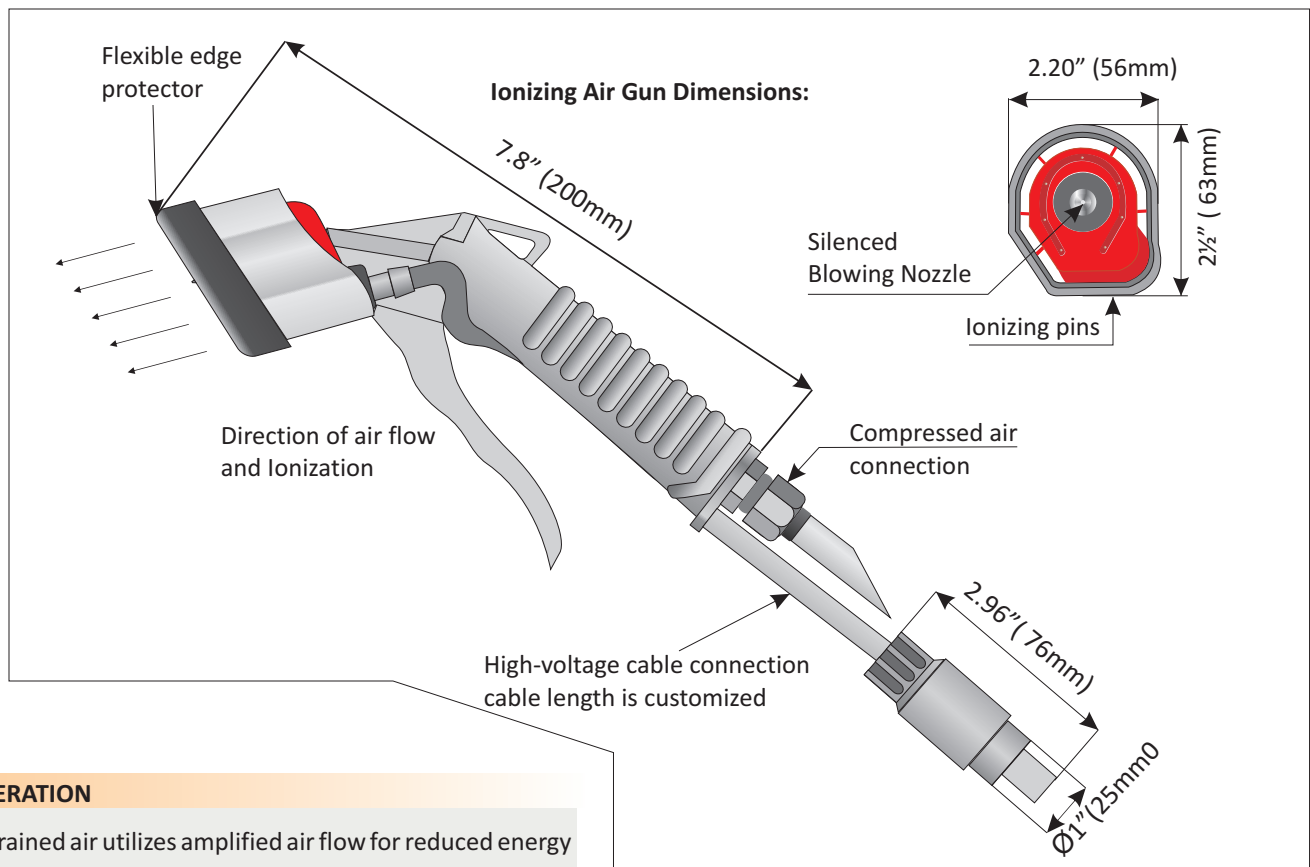
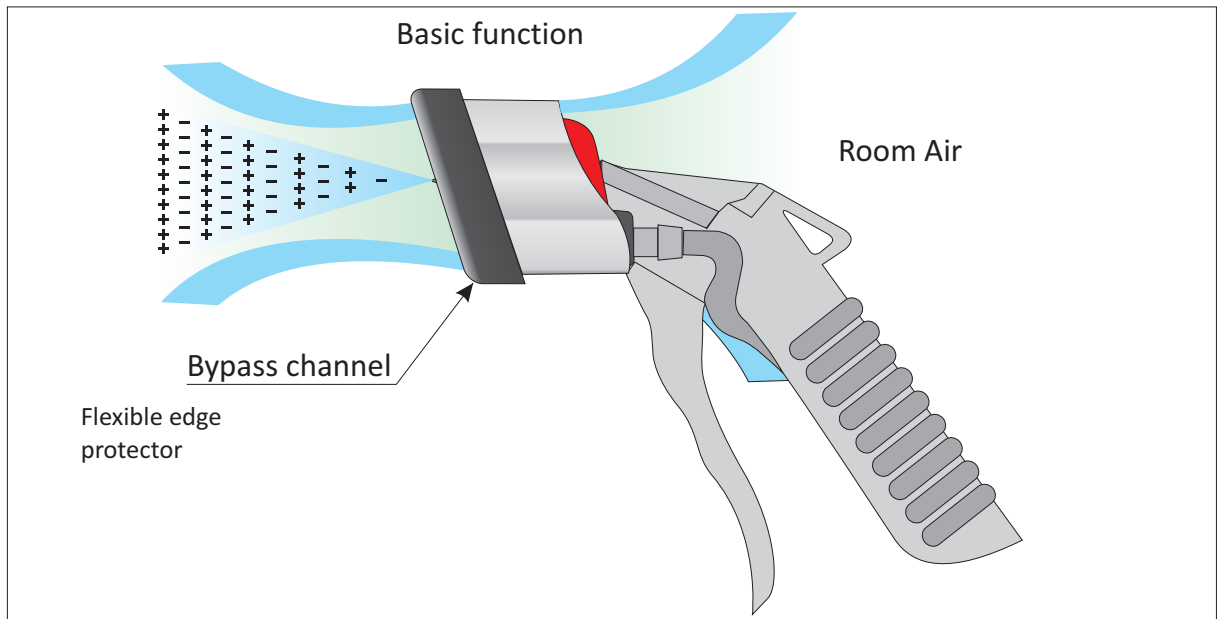

OPERATION

Entrained air utilizes amplified air flow for reduced energy use. The Ionizing pins are not in the direct path of the airflow minimizing dirt buildup and preventing premature failure that can occur with pins directly in the path of the air flow.

PART NO.	DESCRIPTION
18001	LG IONIZING GUN ONLY c/w 15 feet of cable
18101	LG IONIZING GUN c/w 15 feet of cable Plus ENC-2 Power Supply (2 outlet)

STATIC ELIMINATORS

Ionizing Nozzles

The **Ring Ionizer - Ionizing Nozzles** are a highly effective the discharging and cleaning of surfaces - in particular of non-conductive materials. The Nozzles can also be mounted to a handgun if they need to be converted to manual use.

Ring Ionizer Model 17200 and Model 17203 (with Air Gun) This “mini”

version is particularly suited for the discharge of very small areas and components in confined work spaces. It is light, flexible and easy to handle, and its robust design makes this unit the lonizer of choice for many discharge processes.

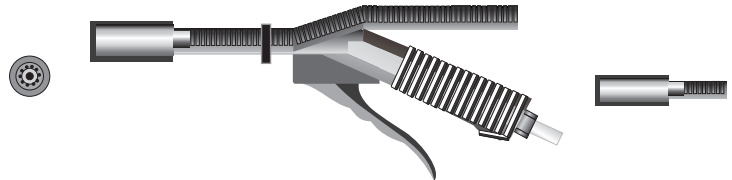

Ring Ionizer Model 17195 and Model 17196 (with Air Gun)

This ring ionizer is light, robust and easy to handle with ergonomic design when used with an Air Gun.



Ring Ionizer Model 17194 and Model 17187 (with Air Gun)

The largest Nozzle, very heavy duty and robust for larger area applications.

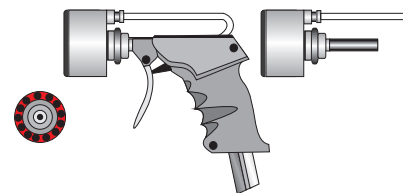

TECHNICAL DATA

Model No.	17200 / 17203	17195 / 17196	17194 / 17187
Nozzle Size	Ø 0.8" (20 mm)	Ø 1.3" (32mm)	Ø 2.5" (65mm)
Weight With air gun But no air hose	Ø 0.1" (2mm) Sollid Stream nozzle	3 X Ø 0.1"(1.6mm) Solid Stream nozzle exchangeable	Ø 0.1" (2mm) Flat get nozzle exchangeable
	0.44 pounds(0.2kg)	0.88 pounds (0.4kg)	1.32 pounds (0.6kg)
Weight With air gun But no air hose	1.1 pound (0.5kg)	1.32 pounds (0.6kg)	2.2 pound (1.0kg)
Air Consumption	According to table depending on pressure		
Optimum pressure	Approx.3bar (43.5 psig)		
Operating temperature	-4°F (-20+°c) to122°F (+50°c)		

STATIC ELIMINATORS - IONIZING NOZZLES

PART NO.	DESCRIPTION
17200	20 mm (0.8 inches) RING IONIZER NOZZLE /w 6 feet (2 m) cable
17203	20 mm (0.8 inches) RING IONIZER NOZZLE /w 6 feet (2 m) cable with air gun
17195	32mm (1.3 inches) RING IONIZER NOZZLE /w 6 feet (2 m) cable
17196	32 mm (1.3 inches) RING IONIZER NOZZLE /w 6 feet (2 m) cable with air gun
17194	65 mm (2.5 inches) RING IONIZER NOZZLE /w 6 feet (2 m) cable
17187	65 mm (2.5 inches) RING IONIZER NOZZLE /w 6 feet (2 m) cable with air gun

ONE POINT IONIZER:

The **One-Point-Ionizer OPI** was developed for the neutralization of tiny parts. This ionizer is perfectly suited for mounting in places where there is little room. The plug of the electrode must simply be connected to the power supply and the unit can be quickly set into operation without tools.

The One-Point-Ionizer **OPI** has proven its value repeatedly in daily use, e.g. in the medical industry. The **OPI** can also be equipped with compressed air (Mini-Jet Ionizer).

NOTE: The pin carries high voltage and must not be touched while in operation.

DIMENSIONS:

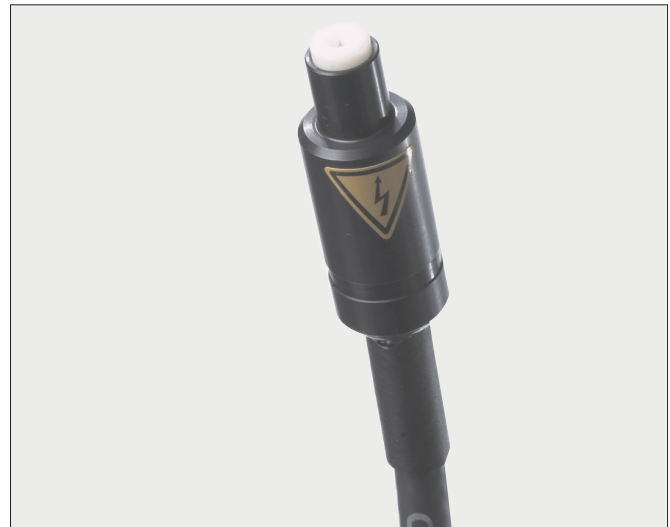
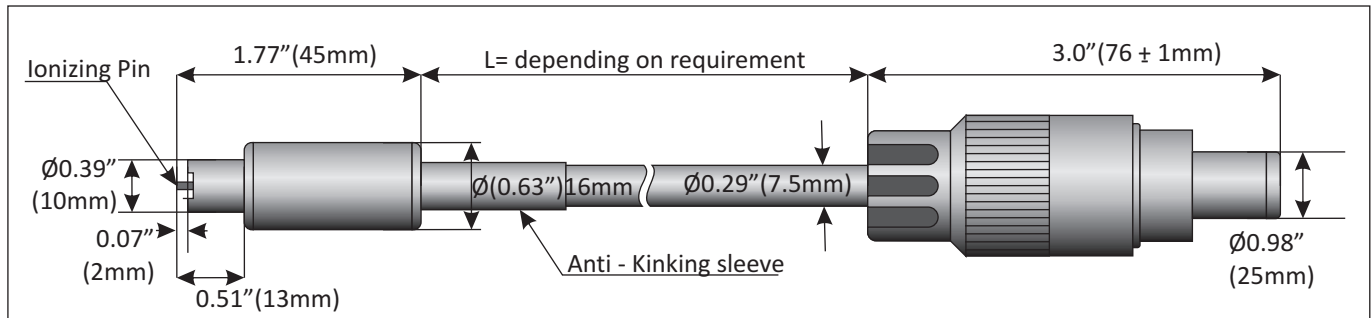

TECHNICAL:

TYPE	OPI INSEPARABLE HV-CABLE, ATTACHED PERMANENTLY TO THE BAR
Diameter	0.63" (16 mm)
Length	1.77" (45 mm)
Operating temperature	41°F to 122°F (+5°C to +50°C)
Optimum effective distance	1.18" (30 mm)
Smallest bending radius (cable)	R 50

PART NO.	DESCRIPTION
17510	ONE POINT SPOT IONIZER c/w 6 feet (2 meters) cable.
17610	MINI-JET IONIZER (JET + ONE SPOT ASSEMBLED)

MINI JET IONIZER:

The Haug Mini Jet Ionizer neutralizes electrostatic spot charges with air support, great efficiency and right force over a small flat area. This unit proves its efficiency especially in mounting places where there is little room or where mounting is very complicated. Applications include injection molding for the elimination of material particles or for cleaning of pendants. It encompasses the use of the One Point Ionizer with a flat plastic Nozzle.



STATIC ELIMINATORS

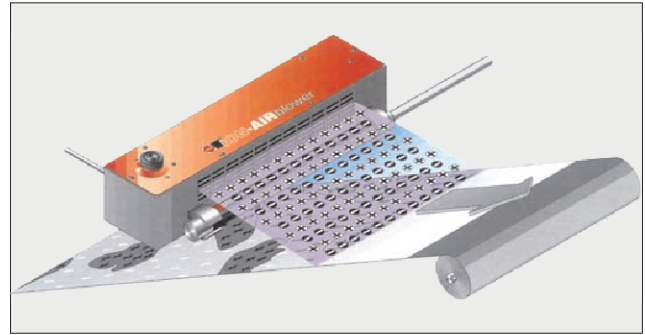
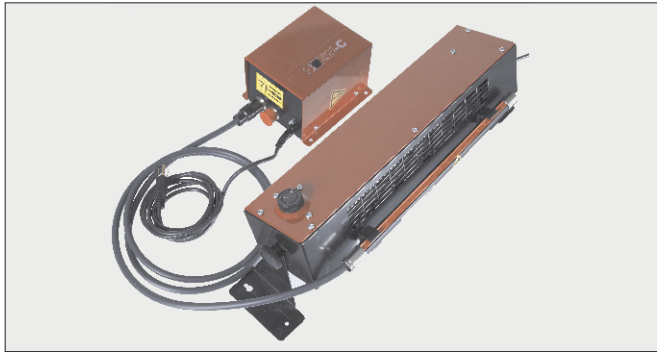

Ion Blowers:

Where air is required to affect static removal at a distance, and blowoff force is not required, and compressed air is not available but there is adequate space, the Ion Blower can be used with either the standard Model RN static bar or the extra powerful Model VS bar. These units are easy to mount and simple to operate with an adjustable fan. The bar is located outside the blower for easy maintenance and cleaning. Three different sizes are available - small, medium and large lengths.

Either the standard strength Model RN static bar is supplied and for difficult highly charged surfaces the extra strength Model VS bar is used.

Applications:

- ▶ On Winding and Unwinding Systems (especially for Films and Foil) on Injection Molds and their handling systems
- ▶ In the production of circuit boards
- ▶ In the electronic Industry
- ▶ In the plastics and packaging industry

The Ion Air Blower becomes very flexible when a larger operating length is required. Several Units can be 'daisy-chained' in series. In this case, only one Ionizing Bar and one Power Supply is required.

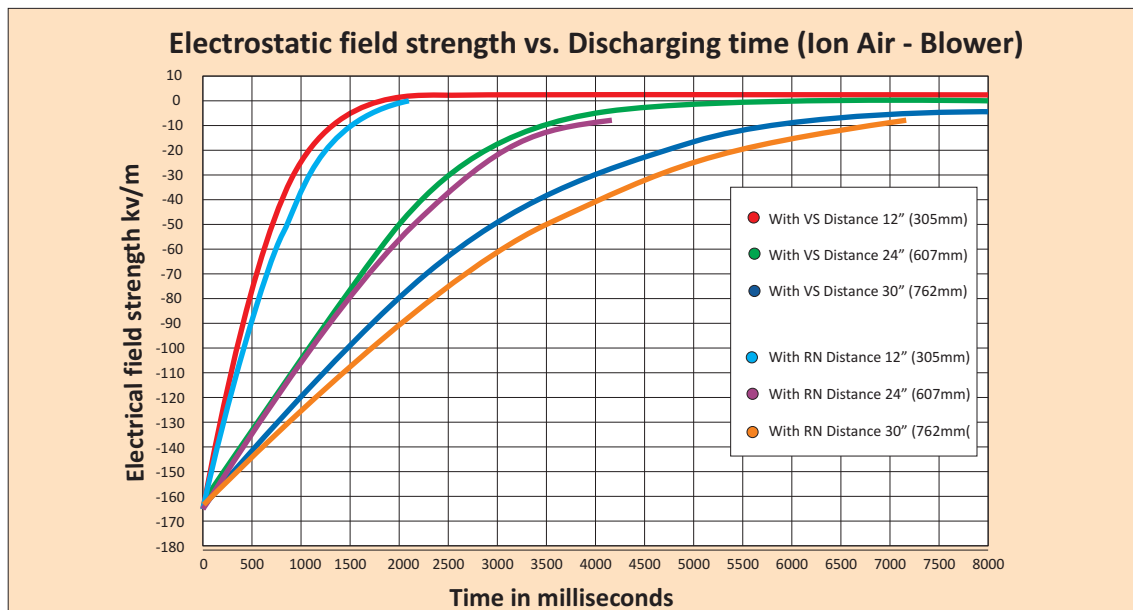
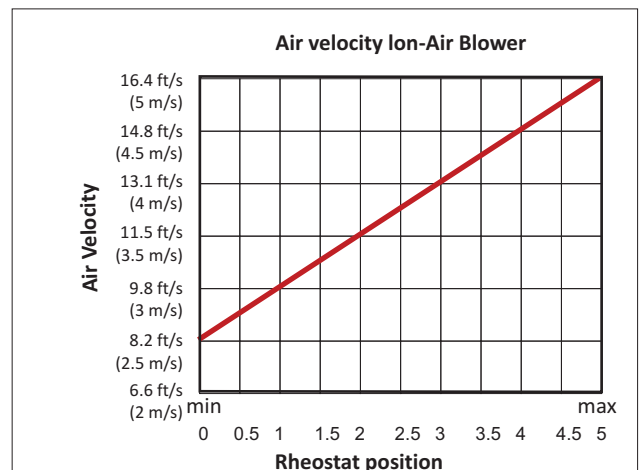

Technical Specifications Ion-Air blower	
Size	Unit with 2 retaining holders, with adjustable screws and base
Length A	Length 18" (457 mm), weight 2.7 kg (5.95lb) max. bar length 14.96" (380 mm)
Length B	Length 32" (813mm), weight 3.6 kg (7.93lb) max. bar length 30.70" (780 mm)
Length C	Length 61.37" (1549 mm), weight 7.0 kg (15.43lb) max. bar length 59.4" (1510 mm)
Rated supply voltage	115 V / 230 V
Rated frequency	50-60 Hz

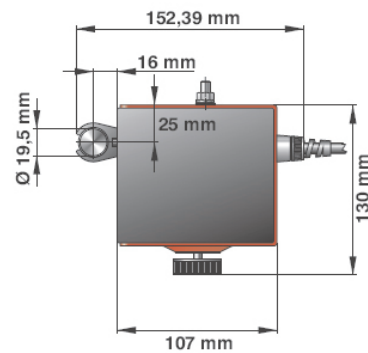
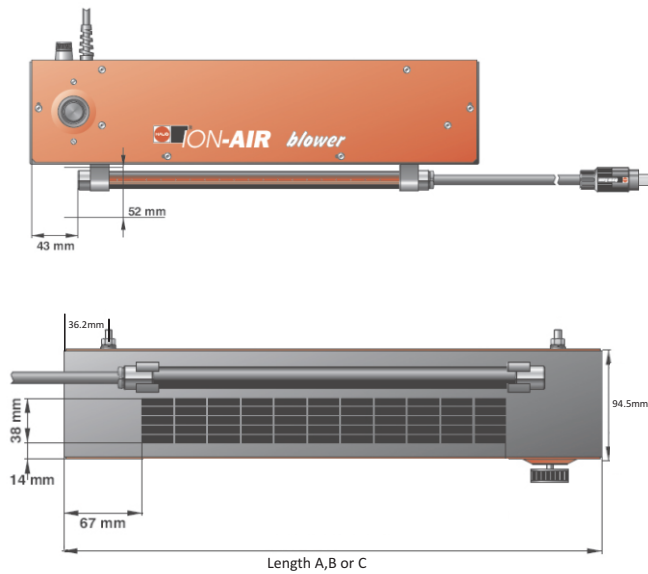

(Mounting Brackets not shown)

ION BLOWERS - when compressed air is NOT an option

PART NO.	DESCRIPTION
17001	Small blower 18" (457mm) c/w standard RN static bar & ENC power supply, 110V
17002	Medium blower 32" (813mm) c/w standard RN static bar & ENC power supply, 110V
17003	Large blower 60" (1549mm) c/w standard RN static bar & ENC power supply, 110V
17004	Small blower 18" (457mm) c/w standard RN static bar & ENC power supply, 220V
17005	Medium blower 32" (813mm) c/w standard RN static bar & ENC power supply, 220V
17006	Large blower 60" (1549mm) c/w standard RN static bar & ENC power supply, 220V
17011	Small blower 18" (457mm) c/w super triple VS static bar and ENC power supply, 110V
17012	Medium blower 32" (813mm) c/w super triple VS static bar and ENC power supply, 110V
17013	Large blower 60" (1549mm) c/w super triple VS static bar and ENC power supply, 110V
17014	Small blower 18" (457mm) c/w super triple VS static bar and ENC power supply, 220V
17015	Medium blower 32" (813mm) c/w super triple VS static bar and ENC power supply, 2200V
17016	Large blower 60" (1549mm) c/w super triple VS static bar and ENC power supply, 220V

Static Testing:



Multicheck Model 80301 -tests if static bars and power supplies are working. The high-voltage test unit Multicheck is a performance testing unit for any power supply and for HAUG ionization units. Unlike cheap AC Testers which only show if power is going into power supplies or static bars, the Multicheck actually indicates if a power supply or bar is working. As you get close to the static bar, or power supply, a red light goes on indicating power to the unit, then if there is adequate voltage to make the system work, the light goes green. A minimum voltage of 3600 volts is required to insure that a static elimination system is working. The Multicheck light will turn green if you have that voltage. AC Testers will NOT do this and are not an adequate indicator so be wary of marketing ploys which may offer AC testers as an accurate device for testing power supplies or static bars.

For testing power packs, the red measuring probe is inserted into the high-voltage socket as far as it will go. After pressing the red push button the LED will illuminate green if the unit functions correctly. In case of malfunction, the LED will illuminate in red or no display at all is visible

For testing ionizing units the test unit is moved vertically towards the ionizing tips. The LED will flash red; when the probe makes contact, the LED will illuminate in green if the ionizing unit functions correctly.



Hand Held Static Meter Model 80302 - used to indicate static charge on parts, sheets and webs. The Hand Held "Static Control" meter is reasonably priced and easy to handle. It is operated using an ON/OFF soft key (with circuit-breaker) and two further soft keys for the 0-100 and 0-1000 kV/m measuring ranges. The meter is battery powered. It should be part of any basic equipment of every electrical engineering workshop. It is rugged and durable for use in all types of plants operations.



Hand Held Static 1 Digital Static Meter Model 80303 - The Static 1 is a small hand-held field strength meter with digital display for measuring electrostatic charges in Volts and is used if more accurate readings are required than with the standard hand held meter. In order to obtain optimum results, the distance between test object and sensor head - depending on the degree of charge and the condition of the objects' surface - can be selected incrementally. The device is equipped with a Hold function to keep the measured value stored on the display. The integrated micro-computer automatically converts the measured field strength into the equivalent charge in Volt.

Static Meters

PART NO.	DESCRIPTION
80301	Multicheck Unit to test if bars and power supplies working
80302	Hand Held Static Meter
80303	Hand Held Static 1 Digital Static Meter

